

City of Redlands

Redlands Fire Department

35 Cajon Street Suite 12, Redlands CA. 92373

Phone: (909) 798-7601 Fax: (909) 798-7602

fireprevention@cityofredlands.org

Underground Piping for Private Hydrants & Sprinkler Supply Line

PURPOSE

The provision of adequate water supplies and distribution systems for fire suppression is a fundamental component of risk reduction. The purpose of this guideline is to provide the basic information necessary to meet minimum requirements for the design and installation of private hydrant and/or sprinkler supply underground piping in accordance with the provisions of the 2022 California Fire Code (CFC), the 2022 California Building Code (CBC), and the 2019 editions of NFPA 24, NFPA 13, NFPA 13R, and locally adopted amendments to these codes.

SCOPE

This guideline is applicable to all private underground piping for hydrants and/or sprinkler supply lines within the City of Redlands, Redlands Fire Department (RFD). This guideline is not applicable to underground piping serving fire sprinkler systems designed in accordance with 2022 NFPA 13D and some systems designed in accordance with 2022 NFPA 13R.

SUBMITTAL REQUIREMENTS

1. General

- A. Plans for all private underground piping for private hydrants and/or sprinkler supply line(s) shall be submitted to RFD for review and approval prior to installation.
- B. All plan review submittals are required to be electronic format, with a final stamped version printed for field installation and inspection reference.

- C. Plans shall be legible, scaled to nationally recognized standards, and printed as a blue- or blackline drawing. The RFD does not accept either pen and ink plans or pen & ink changes to blue-line plans.
- D. A current (within six months), completed Water Availability form shall accompany plans.

Note: City of Redlands Water Division coordinates water fire flow tests as Encroachment Permits.

2. Information to be provided on the title page

- A. Applicable codes and standards used for the system design (e.g., 2022 CFC, 2022 CBC, 2019 NFPA 24, etc.).
- B. Project location, including the full legal address of the facility, and building number(s) if applicable; tract or parcel number.
- C. The contractor's name, telephone number, address, and California State contractor's license number and classification. Contractors must possess a valid A, C16, or C34 license or be registered as a Professional Engineer (PE). *Note: If the piping plan is designed by a PE, the plan shall contain the name, license number, and classification of the installing contractor, along with the PE wet stamp. If this information is not available at the time the plans are submitted, proof of compliance with this requirement must be provided to the RFD at time of inspection.*

3. Additional Required Information

- A. Location of public mains and all public hydrants within 300 feet of the site.
- B. Location of all valves. Specify the type for each (e.g., post indicator valve (PIV), key gate valve, system control valve, double detector check (DDC) assembly, outside stem and yoke (OS&Y), etc.).
- C. PIVs or other approved indicating valves, shall be located a minimum of 40 feet from the building served. Where it is *impractical* to locate control valve(s) 40 feet from the building served, they may be located closer by one of the following methods:
 - 1) Approved wall mount indicating valves: Located on exterior walls without openings within 15 feet of the valve/s.
 - 2) Valve room: When the valve is placed in a room separated from the building by a one-hour fire barrier and the room is accessible from outside.
 - 3) Exterior risers: The valve may be placed in locations adjacent to exterior walls without openings within 15 feet of the valve.
 - 4) An approved manner acceptable by RFD.

- D. Pipe size, class, and type; specify lined or unlined if applicable.
- E. Indicate that ferrous pipe and fittings (excluding stainless steel 316) shall be encased in loose-fitting polyethylene *tubing* (pipe shall not be wrapped in polyethylene sheets) and that ferrous joints, pipe, and fittings shall be coated with asphaltic sealant or equivalent to inhibit corrosion. Exposed edges, cuts, and tears shall be tightly taped to inhibit water infiltration. Where joints are present in tubing, a minimum one-foot overlap shall be provided. Tubing shall extend three feet beyond transition between areas where ferrous pipe or fittings are used and where non-ferrous pipe begins.
- F. All bolts used for underground connections, including T bolts, shall be 316 stainless steel. Asphaltic sealants (and other opaque sealants) shall not be used to coat bolts (this is to ensure bolts can still be verified as 316 stainless steel during inspection).
- G. Thrust block locations, or specify the means of restraint as approved by 2019 NFPA 24.
- H. Location of the fire department connection (FDC). FDCs shall be on the address side of the building and located immediately adjacent to the approved fire department access road. The FDC shall be in a position allowing hose lines to be readily and conveniently attached and does not cross fire department access roads. The FDC shall contain a minimum of *two 2½"* inlets. When the sprinkler demand is 500 gpm or greater (including the interior hose stream demand) or a standpipe system is included, *four 2½"* inlets shall be provided. The FDC shall be a listed assembly, i.e. Potter-Roemer FDC Models 5761-5764, 5775, 5776, 5780, 5781, 5785, 5786, Guardian FDC Models 6224, 6226, 6242, 6244, or similar listed devices. Note: These are just examples of the models that would be accepted by RFD. RFD does not endorse any specific manufacturer.
- I. FDC's shall be no more than 50 feet from a public hydrant. The FDC may be located within 50 feet of a private hydrant if the FDC is connected to the fire sprinkler system by a dedicated pipe that connects on the system side (i.e., downstream) of the sprinkler system check valve.
- J. FDCs, PIVs, and backflow assemblies shall be readily visible and accessible from the fire lane. Vegetation may be used to screen backflow assemblies on the side that does not face the fire department access roadway.
- K. FDCs and PIVs, shall be painted OSHA safety red.
- L. FDCs, PIVs, and DDCs, shall have durable, legible signs clearly indicating the address of the facility they serve or, where appropriate, their function (e.g., "Sectional Valve 1 of 2"). Signs shall be securely attached to the device.

Note: See Redlands Fire Department Guideline 23-1 (FP & Utility Identification Signs) for specifications.

- M. Large private fire service mains shall have post indicating (PIV) type sectional control valves at appropriate points in order to permit isolation of the system in the event of a break or during repair or extension.

Note: Sectional PIV control valves on the fire service main shall be coordinate to ensure a maximum of 5 appurtenance (fire hydrants or fire sprinkler riser laterals) are in each isolation zone.

- N. Provide a fire riser detail. When a pipe runs under footings or foundations of the building, a single corrosion resistant stainless steel pipe unit assembly is required. The pipe shall terminate a maximum of 18 inches from the exterior wall and six inches above the finished floor. A minimum of 2 inches clearance (annular space) shall be provided where the pipe passes through the floor or wall. A minimum of 12 inch vertical clearance shall be provide between the foundation/footer and steel pipe unit assembly.

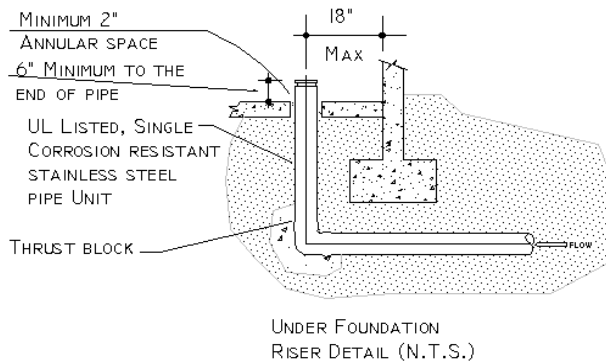

- O. Provide a typical trench detail/section showing the depth of bury and thickness of sand bedding above and below the pipe.

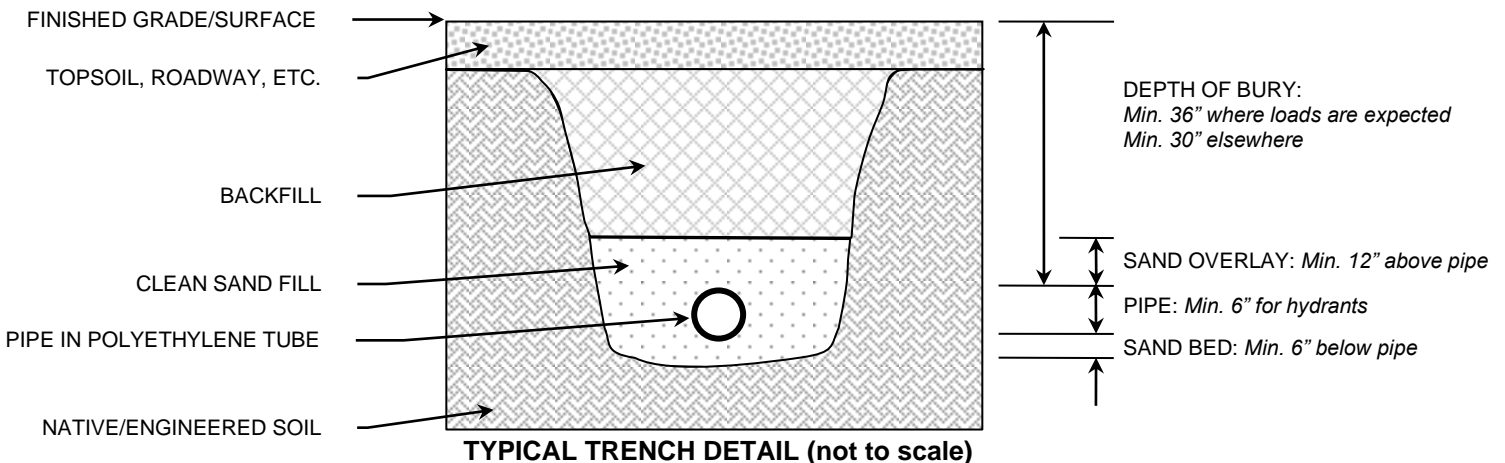

- O. The attached “NOTES FOR UNDERGROUND PIPING FOR PRIVATE HYDRANTS AND SPRINKLERS” shall be placed, verbatim, on all underground plans. The attached “NOTES FOR THRUST BLOCK RESTRAINTS” shall be placed, verbatim, on all underground plans that use thrust blocks as the restraining method.

4. **Underground Points of Connection**

Any development within the City of Redlands that consists of more than a single structure on a commercially developed site; multiple floor commercial structures; multi-family commercial residences or fire flow requirements in excess of 2000 gpm will require a two point of connection full looped fire supply to the development. All required onsite fire hydrants will be supplied from this looped system and will be private to the development. When there are practical difficulties involved in carrying out the provisions of this ordinance the Fire Code Official is authorized to grant modifications for individual cases on application in writing by the owner or a duly authorized representative. The code official shall first find that a special reason makes enforcement of the strict letter of the ordinance impractical and any modification or change does not lessen any fire protection requirements. If so changes or modifications may be approved by the Fire Code Official or Fire Chief.

5. **Underground Service for NFPA 13R Systems**

Underground service shall comply with one of the following designs based upon the parameters described:

- A. The system design shall comply with NFPA 13 and NFPA 24 (see Sections 1 through 3 above) when:
 - 1) Serving more than one R-1, R-2, or R-4 occupancy, *or*
 - 2) The FDC is located between the city supply and sprinkler riser check valve.
- B. The system design shall comply with NFPA 13R and the California Plumbing Code (CPC) when:

1) Serving a single R-1, R-2, or R-4 occupancy, *and*

2) The FDC is located downstream of (i.e., after) the sprinkler system riser check valve. The underground system may be interconnected with the building's domestic water supply line or may be a dedicated fire line. The FDC shall also comply with relevant requirements listed in this guideline including, but not limited to, identification, painting, accessibility, and orientation.

City of Redlands

NOTES FOR UNDERGROUND PIPING FOR PRIVATE HYDRANTS & SPRINKLERS

All of the notes listed below shall be placed, verbatim, on the plan under the heading **“CITY OF REDLANDS NOTES”**

GENERAL INSPECTION REQUIREMENTS

1. A minimum of three RFD inspections are required for underground piping serving sprinkler systems and/or private hydrants: 1) Pre-pour inspection; 2) Hydrostatic testing; 3) Flush inspection.
2. Request for inspections are taken Monday through Thursday from 7am to 5pm. A minimum of 48-hour notice is required. However, inspection dates and times are set according to the inspector's availability. Requests needed sooner are also at the availability of the Inspector.
3. Contact RFD Community Risk Reduction Division at (909) 798-7601 or via email at fireprevention@cityofredlands.org to schedule inspections.
4. Request for inspections can only be taken from the contractor who was issued this permit.
5. Approved plans shall be kept on the job site at all times while work is in progress. No work is permitted without approved plans and permits.
6. **Pre-pour inspection:** Thrust block excavation shall be completed, but thrust blocks shall not be poured. All pipe shall be in place and exposed for visual inspection. Pipe shall be laid on a minimum six-inch bed of clean sand. Trenches shall be of a sufficient depth to allow the required cover above pipe. Ferrous pipe and fittings shall be encased in polyethylene tubing (not wrapped) and tightly taped to inhibit water infiltration. Ferrous joints (with the exception of stainless steel 316) shall be coated with asphaltic sealant or other corrosion retarding material. See items 11 – 19, 21 and 22 below for detailed requirements.
7. **Hydro Testing:** Thrust blocks shall be in place. Pipe shall be center-loaded with clean sand to prevent uplift, but all joints shall remain exposed. The system shall be hydrostatically tested at 200 psi (or 50 psi over maximum static pressure, whichever is greater) for a duration of at least two hours prior to the arrival of the RFD inspector. See item 16 for detailed requirements.
8. **Flush inspection:** All portions of the underground system shall be flushed to remove debris prior to connection to overhead piping. Flow shall be through a minimum of a four-inch hose or pipe, unless otherwise approved by the RFD inspector prior to scheduling the flush. Hose or pipe shall be restrained to prevent injury and damage. Discharged water shall be collected or diverted in accordance with applicable SWPPP/NPDES provisions. The local public works department, water district, and/or other applicable agency shall be notified of the scheduled flush by the contractor. The RFD flush and hydro inspections may be scheduled concurrently. See items 11, 18, and 20 – 23 below for detailed requirements.
9. Upon flush inspection or prior to final sprinkler or site inspection, all detector check assemblies, control valves, and fire department connections (FDC) shall be clearly labeled with the address(es) served by the device. Address signs shall be securely attached to the device and be of a durable, fade-resistant material which is visible and legible from the fire lane. FDC and four-inch hydrant outlets shall be unobstructed and oriented toward the fire lane. Valves shall be locked in the open position with breakaway locks. All PIV valves and private hydrants shall be painted OSHA safety red. The closest upstream indicating valve to the riser shall be painted OSHA safety red. Hydrant and FDC caps shall be in place. See items 6 – 9, 18, and 20 – 23 for detailed requirements.

GENERAL REQUIREMENTS

6. Installation, inspection, and testing shall conform to 2022 edition of NFPA 13 and 2019 edition NFPA 24. RFD jurisdiction begins at the downstream side of the last valve on the

detector check assembly. Verify design and installation requirements for the portion of the system preceding this point with the local water district.

7. Vegetation shall be selected and maintained in such a manner as to allow immediate location of, and unobstructed access to; all hydrants, control valves, fire department connections, and other devices or areas used for firefighting purposes.
8. A minimum three-foot clearance shall be provided around all hydrants and post indicating valves. A minimum three-foot clearance shall be provided on at least one side of a detector check assembly to allow proper operation of the device. The front of FDC and the adjacent fire access roadway shall be free of any obstructions.
9. Any future modification to the approved private underground piping system is subject to review, inspection, and approval by the RFD.
10. Approval of this plan shall not be interpreted as approval of any information or project conditions other than those items and requirements identified in RFD Guideline, and applicable sections of the 2022 edition of NFPA 13 and 2019 edition NFPA 24. This project may be subject to additional requirements not stated herein upon examination of actual site and project conditions or disclosure of additional information.

PIPE AND TRENCH REQUIREMENTS

11. A 6-inch bed of clean fill sand shall be provided below the pipe and 12-inches above the pipe (total of 18 inches plus outer diameter of the pipe).
12. Pipe shall be buried at least 36" where subject to loading (e.g., driveways, parking lots) and at least 30" elsewhere.
13. All pipe shall be approved for use in fire service systems. Class 150 will be used at a minimum, and class 200 pipe shall be used where the water pressure exceeds 150 psi. The use of galvanized pipe is prohibited when a portion of the system is buried.
14. All ferrous pipe and fittings shall be protected with a loose 8-mil polyethylene tube. Wrapping the pipe in polyethylene sheeting is not acceptable. The ends of the tube and any splices made for tees or other piping components shall be tightly sealed with two-inch tape that is approved for underground use.
15. All bolts used for underground connections, including T bolts, shall be 316 stainless steel. Asphaltic sealants (and other opaque sealants) shall not be used to coat bolts (this is to ensure bolts can still be verified as 316 stainless steel during inspection). All ferrous fittings (with the exception of 316 stainless steel) shall be cleaned and thoroughly coated with asphalt or other corrosion retarding material after assembly and prior to the installation of polyethylene tube
16. Thrust blocks, or another approved method of thrust restraint, shall be provided wherever pipe changes direction.
17. A minimum two-inch clearance shall be provided where the pipe passes through slabs or walls. Underground system shall terminate at the riser flange and placed a maximum of 18 inches from an exterior wall and 6 inches above the slab.
18. The FDC shall contain a minimum of two 2 ½" inlets. When the system design demand, including the interior hose stream demand or a standpipe, is a minimum 500 gpm, four 2 ½" inlets shall be provided. FDCs shall be painted OSHA safety red.
19. Pipe running under a building or building foundation shall be stainless steel and shall not contain mechanical joints.

HYDRANT REQUIREMENTS

20. Private fire hydrants shall be listed with a minimum of one 2 ½" and one 4" outlet. The 4" outlet shall face the fire department access road. All outlets shall be provided with National Standard Threads (NST). Private hydrants shall be painted OSHA safety red.

21. Fire hydrant supply piping shall be a minimum of six inches in diameter. The lowest valve operating nut shall be a minimum of eighteen inches above grade and the hydrant flange shall be a minimum of two inches above grade.
22. A keyed gate valve shall be provided for each hydrant in an accessible location. Keyed gate valves shall be located within six to ten feet of the hydrant in an area that is unobstructed and clearly visible. Valves shall not be located in parking stalls.
23. All fire hydrants shall have a "Blue Reflective Pavement Marker" indicating their location per the RFD standard detailed in Access Guideline. Private hydrants and markers are to be maintained in good condition by the property owner.

INSPECTION REQUIREMENTS

24. Prior to scheduling any fire inspection, all systems are required to be pre-tested. System or inspection failures will result in additional fees.
25. All testing equipment must be disconnected prior to starting the hydrostatic test.
26. - Underground fire service mains serving multiple risers require a gauge at each riser to verify the entire system is being hydrostatically tested.
27. - Approval from City of Redlands Water Department, if not on-site, is required prior to observing any flush.
28. - Trenches shall be clean and free of all trash and debris prior to authorization to back fill.
29. - Underground fire service mains that are covered prior to approval must be made visible for required inspections.
30. - Trenches across fire access roadways must be approved prior to trenching.

PLACE THE FOLLOWING NOTES, VERBATIM, ON THE PLAN:

CITY OF REDLANDS NOTES FOR THRUST BLOCK RESTRAINTS

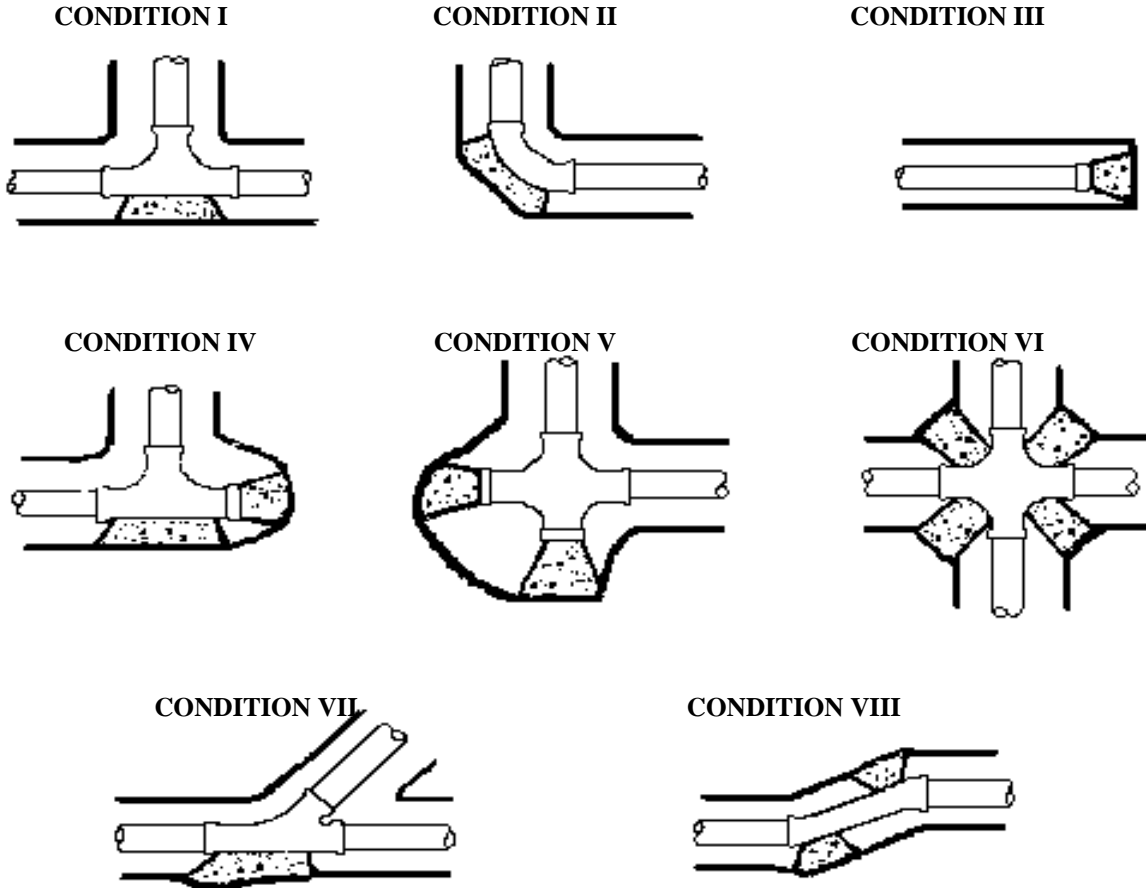

A. THRUST BLOCK BEARING AREA IN SQUARE FEET

Pipe Size	B. CONDITION							
	I	II	III	IV	V	VI	VII	VIII
<6"	2.0	2.9	2.0	2@ 2.0	2@ 2.0	4@ 1.6	2.0	2@ 1.6
6"	4.3	4.0	4.3	2@ 4.3	2@ 4.3	4@ 3.3	4.3	2@ 3.3
8"	7.4	10.6	7.4	2@ 7.4	2@ 7.4	4@ 5.7	7.4	2@ 5.7
10"	12.1	17.1	12.1	2@ 12.1	2@ 12.1	4@ 9.3	12.1	2@ 9.3
12"	17.2	24.1	17.2	2@ 17.2	2@ 17.2	4@ 13.2	17.2	2@ 13.2

NOTES

1. Thrust block areas based on 225 PSI and 2,000 PSF soil pressure with 2 ½ feet of cover minimum.
2. Thrust block bearing faces shall be placed against undisturbed soil, approved compacted backfill, or Class 100-E-100 slurry.
3. Thrust blocks shall be Class 560-C-3250 concrete, unless specified otherwise.
4. To facilitate future removal of thrust blocks and line extension use cardboard separators between blocks, if needed.